

Technical sheet :

MRT 2550 PRIVILEGE PLUS



 **MANITOU**
HANDLING YOUR WORLD

Capacities		Metric
Max. capacity		4999 kg
Max. lifting height		24.70 m
Maximum outreach		21.40 m
Weight and dimensions		
Overall length (with forks)	l1	9.04 m
Length to face of forks	l2	7.84 m
Overall width	b1	2.49 m
Overall height	h17	3.05 m
Overall cab width	b4	0.99 m
Ground clearance	m4	0.35 m
Wheelbase	y	3.05 m
Tilt-up angle	a4	13 °
Tilt-down angle	a5	102 °
Turret rotation		360 °
Overall weight		18900 kg
Forks length / width / section	l / e / s	1200 mm x 150 mm x 50 mm
Wheels		
Tires type		Pneumatic
Standard tires		445/65 R22,5
Drive wheels (front / rear)		2 / 2
Steering mode		2 wheel steer, 4 wheel steer, Crab mode
Stabilisers		
Stabilizers Type		Telescopic Duplex
Controls for stabs		Stabs Commands Individual or Simultaneous
Engine		
Engine brand		Mercedes
Engine norm		Stage IV, Tier 4 final
Engine model		OM 934 LA.E4-5
Engine power (Hp) / power (kW) / rotation		156 Hp / 115 kW @ 1600 rpm
Max. torque / Engine rotation (min)		675 Nm @ 1200 rpm
Number of cylinders - Capacity of cylinders		4 - 5130 cm³
Injection		engine Injection direct
Engine cooling system		Water
Electric circuit		
Number of batteries / Battery voltage		2 x 12 V
12V Battery capacity		120 Ah
Transmission		
Transmission type		Hydrostatic
Number of gears (forward / reverse)		2 / 2
Max. travel speed		40 km/h
Drawbar pull		8700 daN
Parking brake		Automatic Negative Hand-brake
Service brake		Hydraulic
Hydraulics		
Hydraulic pump type		Gear pump
Hydraulic flow		115 l/min
Hydraulic Pressure		275 bar
Hydraulic tank capacity		225 l
Tank capacities		
Engine oil		14 l
Fuel		305 l
Diesel Exhaust fluid (AdBlue® type)		57 l
Noise and vibration		
Noise at driving position (LpA)		79.70 dB
Noise to environment (LwA)		107 dB
Vibration on hands/arms		2.50 m/s²
Miscellaneous		
Steering wheels (front / rear)		2 / 2
Controls		2 Joysticks
Cab certification		Cabin ROPS - FOPS level 2
Attachment recognition system (E-Reco)		Standard

MRT 2550 Privilege Plus - Dimensional drawing

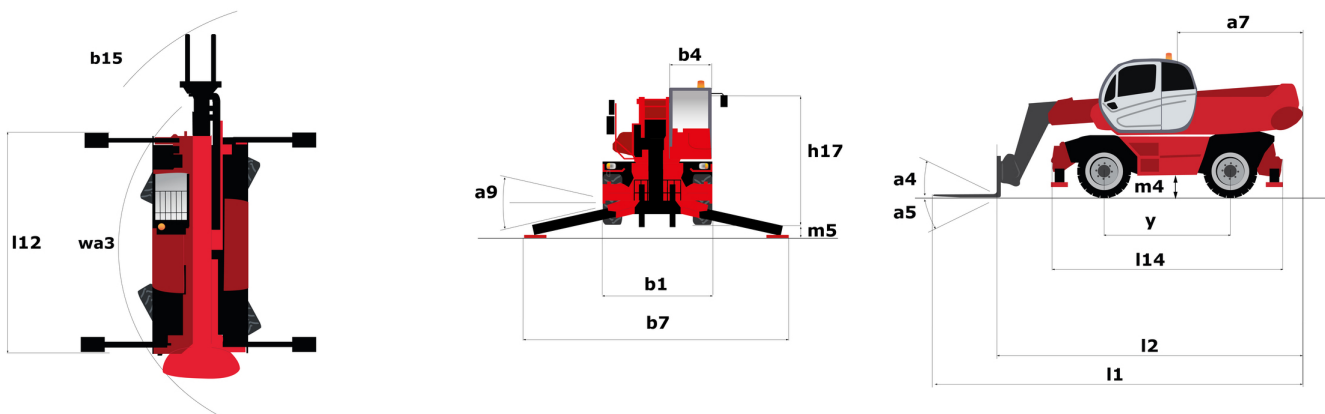

Other data		Metric
Length of frame	l14	5.35 m
Wheelbase	y	3.05 m
Ground clearance	m4	0.35 m
Counterweight offset (turret at 90°)	a7	3.18 m
Overall length at stabilisers	l12	5.19 m
Outer turning radius (with forks)	b15	6.92 m
Overall width with stabilisers extended	b7	5.55 m
Frame leveling corrector	a9	8 °
Ground clearance under front tires on stabilizers	m5	0.23 m

MRT 2550 Privilege Plus - Load chart

Machine on tires with forks Metric

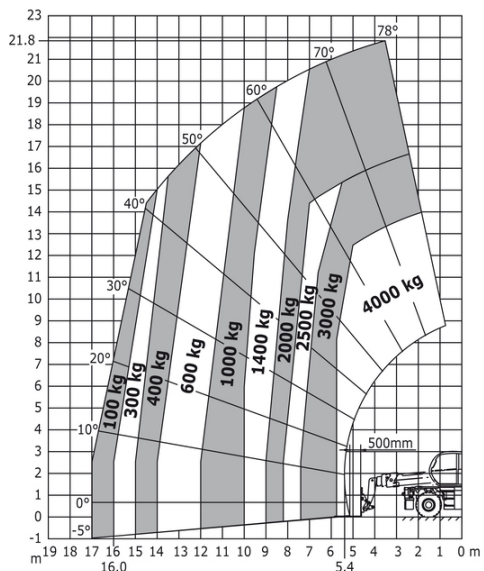

Machine on lowered stabilisers with forks Metric

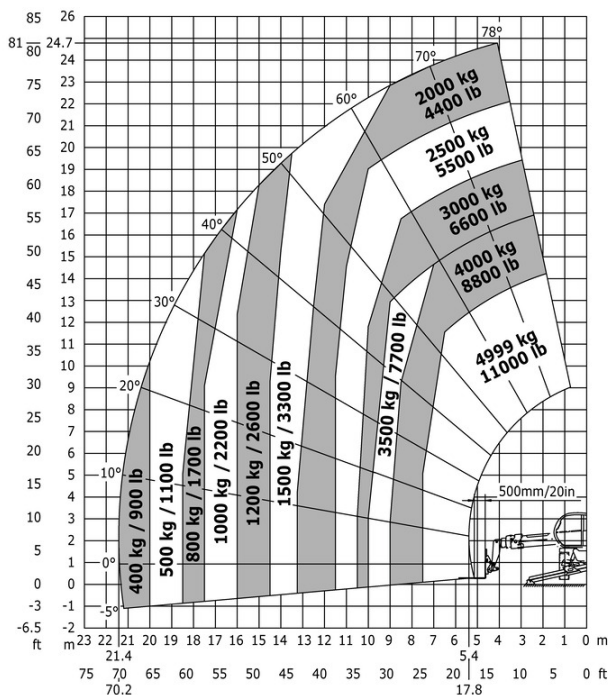

Machine on lowered stabilisers with winch 5000 kg Metric

Machine on lowered stabilisers with 1500 kg jib Metric

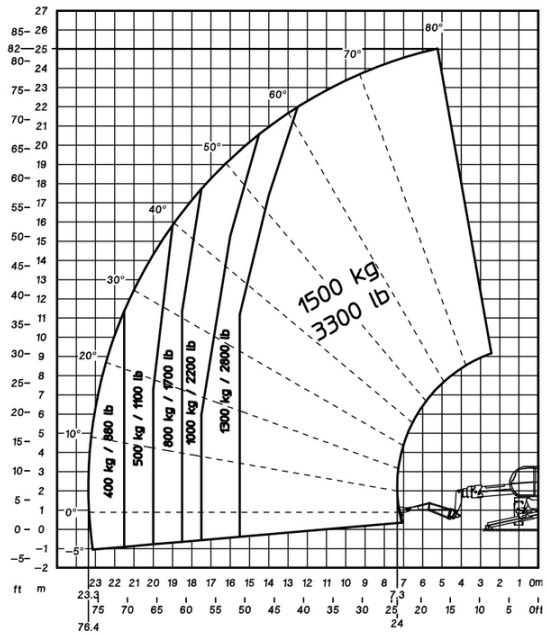
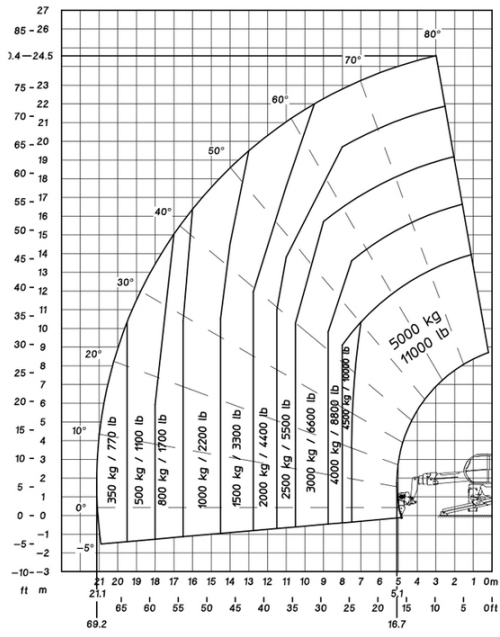

Machine on lowered stabilisers with 365 kg platform Metric Machine on lowered stabilisers with 1000 kg platform Metric

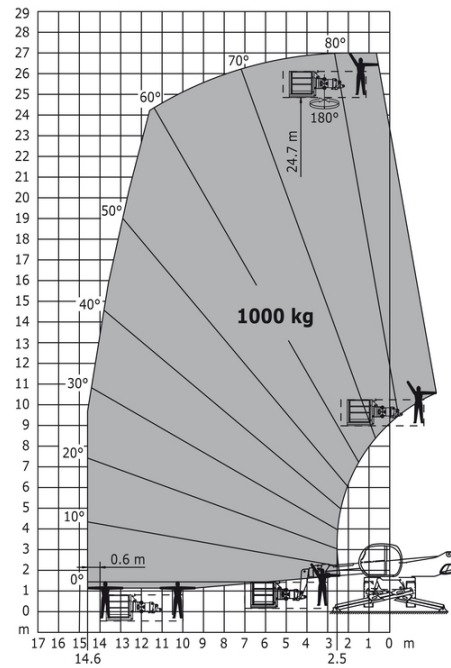
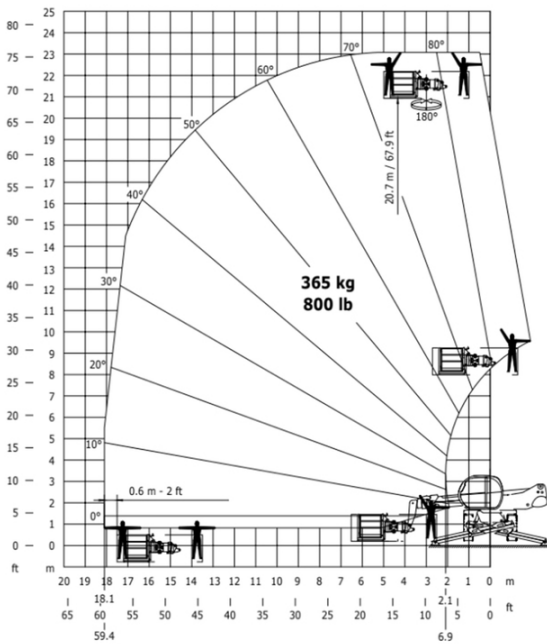

Machine on lowered stabilisers with 3D negative Metric

Machine on lowered stabilisers with 3D positive / negative Metric

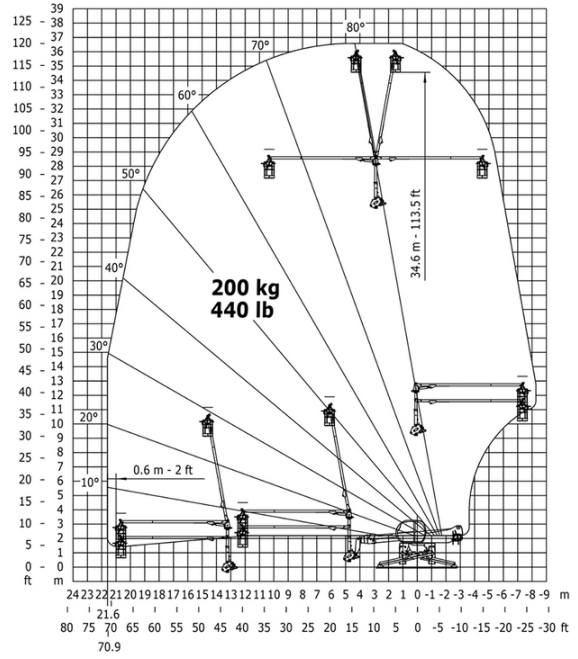
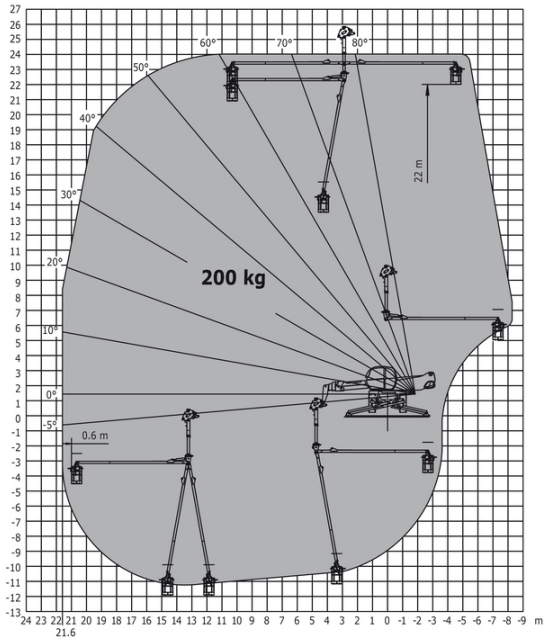



Head Office

B.P. 249 - 430 rue de l'Aubinière

44150 Ancenis Cedex - France

Tel: +33 (0)2 40 09 10 11 - Fax: +33 (0)2 40 09 10 97

www.manitou.com



This publication provides a description of the configuration versions and options for Manitou products, which may differ for equipment. The equipment presented in this brochure may be part of a series, as an option, or it may not be available, depending on the versions. Manitou reserves the right, at any time and without notice, to amend the specifications described and represented. The specifications provided do not bind the manufacturer. For more details, please contact your Manitou agent. This is not a contractually binding document. The presentation of the products is not contractually binding. List of specifications non-exhaustive. The logos as well as the visual identity of the company are owned by Manitou and cannot be used without authorisation. All rights reserved. The photos and diagrams contained in this brochure are only provided for consultation and information purposes.

MANITOU BF SA - Limited company with board of directors - Share capital: 39,668,399 euros - 857 802 508 RCS Nantes